

Luge/bobsled track

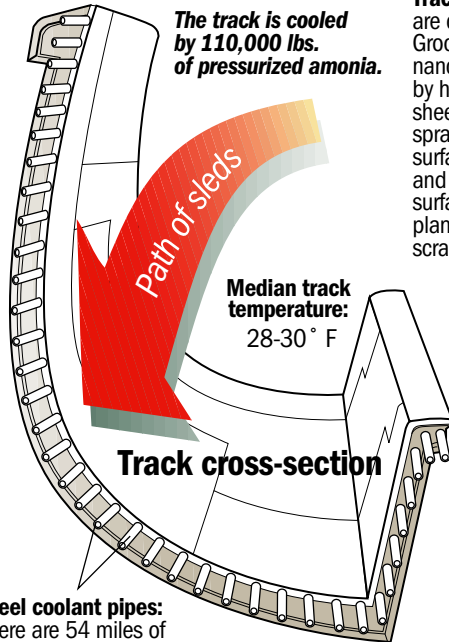

Steel coolant pipes:
There are 54 miles of
1-inch pipe in the track.

*The track is cooled
by 110,000 lbs.
of pressurized ammonia.*

**Median track
temperature:**
28-30° F

Track cooling systems are computerized. Grooming and maintenance must be done by hand. The ice sheet is achieved by spraying the track surface with water and shaving the surface with a plane-like ice scraper.

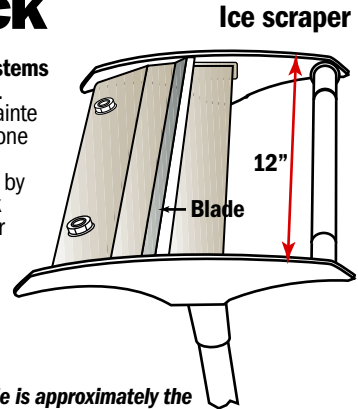

Ice scraper

*Handle is approximately the
length of a broom handle.*

Track facts

- **53 hydrants** provide water for the track
- **A crew of 9** maintains the track
- **The ice sheet** is 1.5 to 2 inches thick.
- **Top speeds:**
Bobsled- up to 90 mph
Luge- up to 80 mph